

## CONTROL CABINET INTERNAL FAN



- ▶ Efficient air circulation in the control cabinet
- ▶ Adjustable airflow
- ▶ Protection against local hot spots
- ▶ Versions with thermostat available
- ▶ Quick and easy integration
- ▶ Custom versions available upon request

VENTILATION

**CE** MADE IN GERMANY

The control cabinet internal fan consists of a terminal block and a fan designed to circulate air efficiently within control cabinets. By ensuring an even distribution of the internal temperature, it prevents localized heat buildup and reduces condensation. The fan can be adjusted along both the vertical and horizontal axes to regulate the airflow. Typical applications include control cabinets, control boxes, and technical enclosures in industrial environments where uniform temperature control of the internal components is required.

### TECHNICAL DATA

Art.-No.	650004	650005	650006
<b>Voltage</b>	24V DC	115V AC @50/60Hz	230V AC @50/60Hz
<b>Current</b>	max. 238mA	260mA / 240mA	140mA / 120mA
<b>Power</b>	5.71W	22 / 20W	22W / 21W
<b>Fan airflow (unimpeded)</b>	183m <sup>3</sup> /h	164 / 198m <sup>3</sup> /h	
<b>Sound level</b>	44.5 dB(A)	45 / 50 dB(A)	
<hr/>			
<b>Weight</b>	590g	945g	
<b>Protection type</b>	IP20		
<b>Type of connection</b>	3-pole connection terminal for wire cross-sections of 0,08mm <sup>2</sup> - 4mm <sup>2</sup>		
<b>Mounting connection</b>	Screw-mounting M6		
<b>Mounting position</b>	Horizontal		
<b>Dimensions (H x W x D)</b>	205x160x48mm		
<b>Operating temperature</b>	-10°C to + 70°C		
<b>Storage temperature</b>	-40°C to + 70°C		
<b>Housing material</b>	Steel, fire-galvanized 2mm		
<b>Certifications</b>	CE		

TECHNICAL DRAWING (SPECIFICATION IN MM)

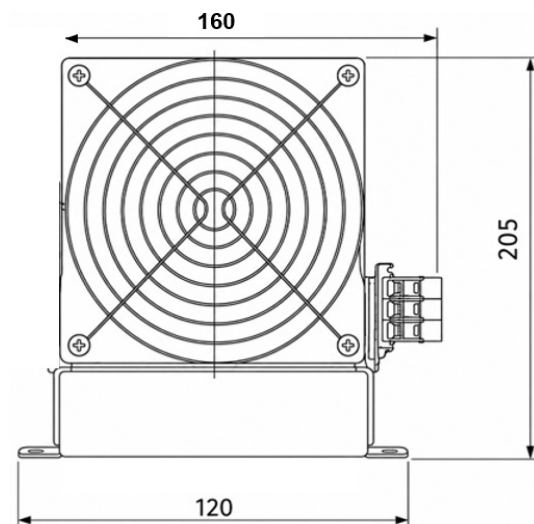

WIRING DIAGRAMM

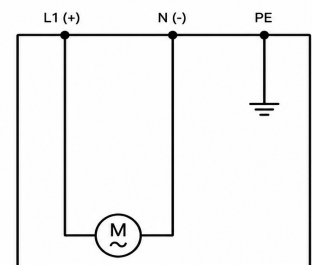

L1 (+) = Supply voltage +  
 N (-) = Supply voltage -  
 PE = Protective Earth (PE)  
 M = Fan (Ventilator)

STATUS: 07|2026

The information on this datasheet contains descriptions and performance characteristics that may not always apply in the specific use case described or may change due to product development. The desired performance characteristics are only binding if expressly agreed upon at the time of contract conclusion. The mentioned technical data has been determined under laboratory conditions according to generally accepted testing procedures. Only to this extent are properties assured. The examination of suitability for the intended purpose or use under operating conditions lies with the customer. We do not provide any warranty for this. Errors, availability, and technical changes are subject to change without notice.